

IMECE2017-71469

CONTROL OF A HEAD STABILIZATION SYSTEM FOR USE IN ROBOTIC DISASTER RESPONSE

Bijo Sebastian

Robotics and Mechatronics Lab
Mechanical Engineering Dept.
Virginia Tech
Blacksburg, VA 24061
bijo7@vt.edu

Adam Williams

Robotics and Mechatronics Lab
Mechanical Engineering Dept.
Virginia Tech
Blacksburg, VA 24061
aw13@vt.edu

Pinhas Ben-Tzvi

Robotics and Mechatronics Lab
Mechanical Engineering Dept.
Virginia Tech
Blacksburg, VA 24061
bentzvi@vt.edu

ABSTRACT

This paper systematically describes the design and validation of a feasible control scheme for a robotic head stabilization system. Over the past few decades there has been a growing need for robotic systems to perform human rescue operations in the event of natural or manmade disasters. Before autonomous or remotely controlled robotic victim extraction can be realized, support systems with the capability to secure the head of a trauma victim in a manner that does not exacerbate existing spinal injuries needs to be developed. The paper starts with a brief description of one such previously developed robotic head stabilization system and examines the various functional requirements from a design and control standpoint. Detailed dynamic analysis of the system is done based on which a force control scheme involving Series Elastic Actuators (SEA) is proposed. The proposed control scheme is then tested on an ADAMS-MATLAB co-simulation where the dynamic head support system is modelled in ADAMS and the force controller in Simulink. Based on the results of the simulation, a physical prototype is integrated and the proposed control scheme is validated through experiments. The results of the simulation and experiment are analyzed, and improvements to the system are proposed for future experimentation. Based on the results of the simulation and experiments, the proposed control was found to successfully meet the desired control metrics in providing accurate force control for the head support device. The paper ends with a discussion on possible modifications to the overall system for it to be used in field robotic rescue.

NOMENCLATURE

J_m	Motor mechanical inertia (Kg-m ²)
L_a	Motor armature inductance (mH)
R_a	Motor armature resistance (Ohm)
T_m	Motor torque (N-m)
V_a	Motor armature voltage (V)
b_m	Motor mechanical damping constant (Nm/rad)

e	Error between applied force and desired force on driving pulley (N)
f_c	Force applied by constant force spring (N)
f_{dh}	Desired force on either side of head (N)
f_{din}	Desired force on driving pulley (N)
f_h	Force applied on either side of head (N)
f_{in}	Force applied on driving pulley (N)
i_a	Motor armature current (A)
k	Extension spring constant (N/m)
k_b	Motor torque constant (N-m/A)
k_d	Derivative gain
k_i	Integral gain
k_p	Proportional gain
l	Pitch of the lead screw on linear actuator (m/rad)
θ_m	Angular displacement of motor (rad)

1 INTRODUCTION

In the course of search and rescue operations, robots can aid first responders in many areas. The use of robots in performing search-related tasks is a well-researched field, and there have been many innovative solutions in that area [1]. Yet a similar problem space that has historically received less attention is the use of robots to physically rescue a person, in part due to a lack of sufficiently advanced technology.

For the past decade the U.S Army has sponsored research into casualty retrieval robots that resulted in several groundbreaking systems [2]. However, none put specific emphasis on the support of the head of the person in transport.

This is a significant shortcoming, for when working with injured people remotely, detection of potentially life-threatening cervical fractures is extremely challenging.

While the typical practice for the treatment of traumatic accidents is to apply both a stabilizing collar to their neck and then provide support for the head with blocks [3], further research has shown that the use of a stabilizing collar can also have deleterious effects on the health of the patient [4]. Additionally, the placement of a stabilizing collar must be performed by a trained medical professional, and as such is outside the scope of what can be performed autonomously by a robot.

Outline

Section 2 provides a background on the existing head support system designs and their potential application in robotic search and rescue. Section 3 describes the detailed dynamic modelling of the system and controller design. Section 4 details the co-simulation setup and results. Section 5 explains the prototype integration followed by Section 6, which elaborates on the experimental validation. Section 7 draws conclusions on the results and describes future work related to this research.

2 BACKGROUND

Technological advancements over the last few years have increased the capabilities of robotic systems, with the majority of robotic research being focused towards search and rescue applications. However, very few systems have been designed for autonomous or semiautonomous human rescue. Some of the advanced mobile robotic platforms that have been proposed in this area include the Robotic Extraction Vehicle (REX) paired with a larger semi-autonomous Robotic Evacuation Vehicle (REV), an anthropomorphic robot called the Battlefield Extraction-Assist Robot (BEAR) that picks up the injured person in its arms and carry them to safety, and an anthropomorphic military version of the robotic nursing assistance robot cRONA [5–7]. Even though all the above-mentioned systems are capable of carrying out human rescue operations, they all neglect providing support to the head and spine during transport. While the anthropomorphic systems (BEAR and CRONA) lift the wounded from the ground then carry them in their arms, the others (REX/REV and similar systems) use manipulators to pull the victim onto the stretcher[8]. In summary, to the knowledge of the authors there are no robotic rescue systems that are capable of providing active head support.

On the other hand, while head and neck stabilization has been common practice in emergency medicine, there have been relatively few robotic attempts to perform the same procedures. One such method is the use of a quick hardening foam, sprayed by a robotic module around the head of the victim to provide an immobilizing support [9]. This was part of a larger modular victim rescue system. However, the foam would adhere the hair and skin of the transported person and was required to be

removed with the aid of a tool. This is a significant drawback, as this entails that someone must be present to assist the removal and possibly use a knife near the face of the injured person to remove them from the foam.

Another area in which robotic head restraints have been explored is in car racing. Currently in NASCAR, a device called the Head and Neck Support (HANS) is worn by drivers to protect their necks in the event of a crash. It consists of straps restraining the head to a frame worn on the shoulders, preventing the head from moving further than the physiological limits of the human body. However, the straps are somewhat restraining and the frame is unwieldy. The MechaNek [10] is an active restraint system utilizing actuated cables fixed to the helmet to provide constant tension to support the head. The unit provides drivers a greater range of motion and reduces the size of the device. In the event of a crash, the controller detects the acceleration, then increases the tension in the cables and protects the driver from cervical spine injury.

The above sections indicate the need for a robotic head stabilization system. One such system designed specifically for autonomous or semi-autonomous robotic rescue mission is described in [11]. The design uses a differential mechanism to provide actuation to head-supporting blocks. Detailed analysis of the system from a control perspective and validation of the proposed control scheme through simulation and experiment will be the subject of this paper. A CAD model of the above-mentioned mechanism can be seen in Fig.1.

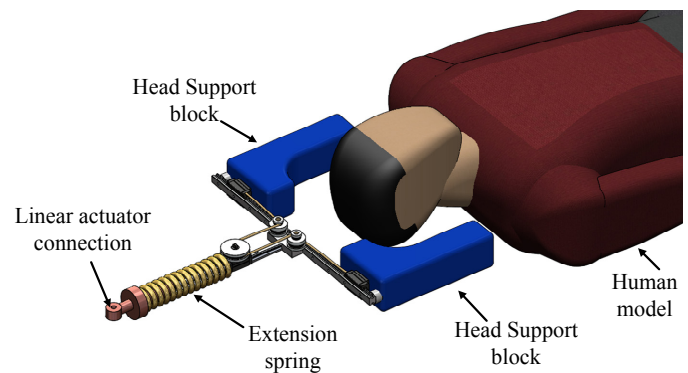

Figure 1. Head Support System

The system consists of two head support blocks that can slide as shown in the figure. The blocks are actuated by a cable that is routed through the redirection and driving pulleys. This creates a differential mechanism such that when the driving pulley is pulled backwards with a force fin, it causes the support blocks to slide providing a total support force fin from both sides of the head. A detailed view of the differential mechanism is shown in Fig.2. The advantage of using a differential mechanism is that, by using a single actuator, the differential mechanism provides the head support blocks the freedom to reach an equilibrium position that may be offset

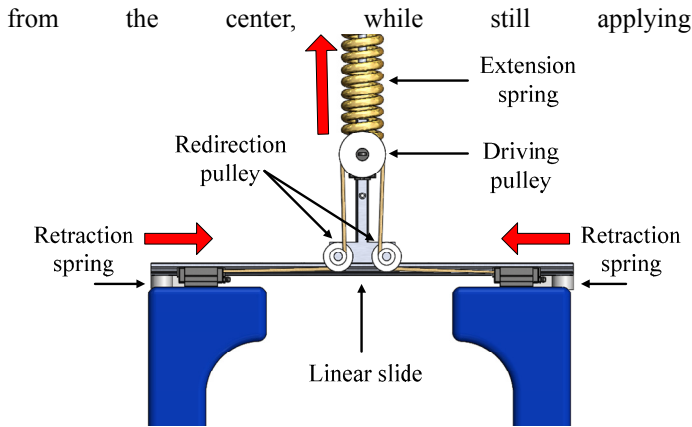

Figure 2. Detailed view of differential mechanism

an equal force on the victims head from both sides. In addition to avoiding potential injuries from forcing the victims head into a central position, the use of differential mechanism better accommodates patients wearing helmets or other kinds of headgear.

When considering the manner in which to control the device, pure position control of the driving pulley is an inadequate approach as it may try to force the injured person's head into an undesired posture, without considering any existing injuries or complications. A better approach is to stabilize the victim's head and neck in the position in which the patient is originally encountered while applying a constant supportive force. Relying on the differential mechanism to provide position compliance, the control system is required to apply a stabilization force within the safe threshold. The system needs to be designed such that under the presence of both position and force disturbances the head blocks should not exert a support force exceeding the set limit.

Force control is done typically using a high quality servomotor coupled with a feedback control algorithm using a stiff load cell [12–14]. However, for the above-mentioned application this method has several shortcomings [15], including the fact that direct drive actuators of desired torque and speed characteristics would be bulky and expensive. The resulting head support system would be too heavy to transport and too expensive for general use in disaster zones. Smaller servomotors with gear reduction, such as the Firgelli linear actuator that was used in this design, introduce significant friction and inertia, reducing the force fidelity of the entire system. Moreover using stiff load cells for force feedback introduces chatter, resulting in sluggish control schemes. In addition, the non-uniform geometry of the human head and clinical requirements of replaceable or serializable head support blocks precludes straightforward measurement of the applied force at the contact point between the head and the support block.

Based on the above requirements the best approach would be the use of a series-elastic actuator (SEA) [15–17]. The SEA

design counteracts the above shortcomings by integrating an elastic element for force measurement and compliance. Similar to the load cell method, SEAs use active force sensing and closed loop control to counteract the effects of friction and inertia. However, force feedback is achieved by directly measuring the compression of the compliant element. A feedback controller calculates the error between the actual force and the desired force, applying appropriate control action to reduce the force error. The advantage is that SEAs introduce significant compliance between the actuator's output and the load, allowing for greatly increased control gains, while still ensuring the absence of chatter and stability. This results in high quality force control with smaller, low precision actuators without the use of expensive load cells.

For the head support system, the driving pulley will be actuated by a linear actuator through an extension spring, as shown in Fig. 1. A linear potentiometer will be used to measure the extension of the spring. As mentioned in [11], constant force retraction springs will be used to bring the head support blocks back into the starting position when the force on the driving pulley is released. The mean time taken to provide neck stabilization by first responders is found to be 5.64 min +/- 1.49 min [18]. Studies performed on the actuation effect of the muscles anchoring the cervical spine show a force of around 16 N perpendicular to the spine corresponds to approximately 35° of rotation[19]. Thus, the system will be designed along these metrics, with a desired force of 10 N to be applied to each side of the head of 10 N, for a total support force of 20 N.

3 SYSTEM DYNAMICS AND CONTROL

In order to design the force controller, detailed mathematical modelling of the system is performed, with the following assumptions:

1. The mass of the foam head support blocks, sliders, cable, redirection and driving pulleys are negligible when compared to the weight of the head of an average person. As such, the inertial effects from these components may be neglected.
2. The sliding friction of head support blocks is small. Therefore, if one support block makes contact with the head before the other, as in the offset case, the contacting block will come to rest causing the free block to move twice as fast. The friction in the pulleys can also be neglected. The free rotation of the driving pulley also ensures that the cables leave the driving pulley at a 90° angle of departure.
3. The retraction force exerted by the constant force spring is assumed constant throughout the range of motion of the support blocks.
4. The spring constant k of the extension spring is assumed constant throughout the range of operation of the system.

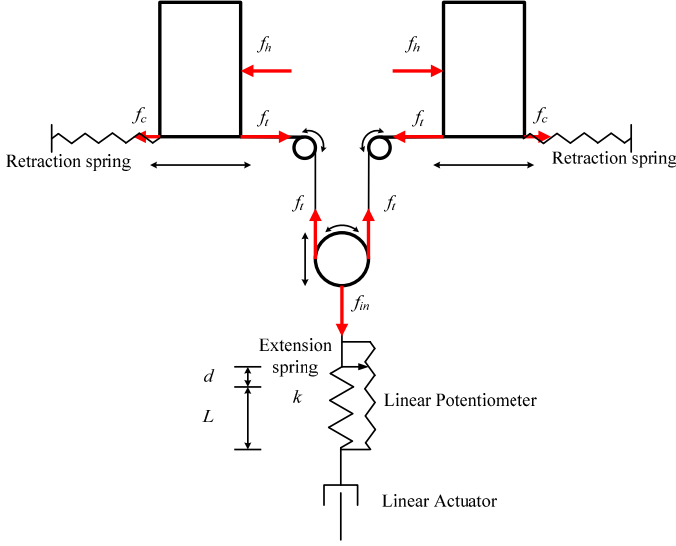

Figure 3. Functional layout of the Head Support System

The functional layout of the system can be seen in Fig. 3. Based on the above assumptions, the dynamic equations of motion of the system in the case where the head support blocks have made contact with the head is derived below:

By applying force balance on the driving pulley, the expression for the force input to the pulley is found to be $f_{in}(t) = 2f_i(t)$, where f_i is the tension in one. The input force is exerted on the pulley by means of linear actuator through the extension spring proportional to the displacement of the spring $f_{in} = kd(t)$.

The deflection of the spring is caused by the displacement of the linear actuator, which can be modelled as an electro mechanical system; DC motor connected to lead screw. The equation for the electrical system is given by $R_a i_a(t) + L_a \dot{i}_a(t) + k_b \dot{\theta}_m(t) = V_a(t)$ while the mechanical system is given by: $J_m \ddot{\theta}_m(t) + b_m \dot{\theta}_m(t) = T_m(t)$. The torque exerted by the motor can be related with the armature current by $T_m(t) = k_b i_a(t)$. Finally, the rotary motion of the motor can be converted into linear motion of the lead screw by the following equation $d(t) = \frac{l}{2\pi} \theta_m(t)$.

Based on the above equations, the open loop transfer function of the system relating the input voltage to the force exerted on the driving pulley is given by:

$$\frac{f_{in}(s)}{V_a(s)} = \frac{l k k_b}{2\pi s (J_m L_a s^2 + (b_m L_a + J_m R_a) s + k_b^2 + b_m R_a)} \quad (1)$$

Once the force exerted by the driving pulley is determined, the force exerted on the head by the support blocks can be obtained by taking the force balance at the head support blocks and the driving pulley:

$$f_h(t) = \frac{f_{in}(t)}{2} - f_c \quad (2)$$

From the above equations, along with assumption (4), we see that $f_h(t)$ can be regulated by controlling $f_{in}(t)$. For the purposes of this paper, we will be using a PID controller with force feedback to achieve the desired results. The feedback is measured by recording the deflection of the spring mechanically in series with the linear actuator, then calculating the applied force. With this feedback path, the feedback law can be written as follows:

$$\begin{aligned} f_{din}(t) &= 2(f_{dh}(t) + f_c) \\ e(t) &= f_{in}(t) - f_{din}(t) \\ \dot{e}(t) &= \dot{f}_{in}(t) \\ V_a(t) &= k_p e(t) + k_i \int e(t) dt + k_d \dot{e}(t) \end{aligned} \quad (3)$$

4 SYSTEM BEHAVIOR SIMULATION

Prior to applying the controller to the physical system, the validity of the proposed control scheme was tested using an MSC ADAMS-Matlab co-simulation. A co-simulation is one in which different parts of a system are modelled in separate software. Continuous exchange of information between the software during the simulation allows for the modelling of the complete system.

The physical head support system was completely modelled in ADAMS, with mass and inertia values corresponding to those of the actual system components. The input to the ADAMS model was the velocity output of the linear actuator, applied to the spring. The model outputs were the extension of the spring (utilized as a feedback for the control algorithm), the force exerted by the blocks on the person's head, and the cable tension. The ADAMS model was then exported to Matlab as a Simulink block.

The linear actuator itself was modelled in Simulink using the Simscape-Electronic libraries. The generic linear actuator block in Simscape models the linear actuator based on force-speed characteristics of the actuator, efficiency of motor and estimated force-independent electrical losses all of which can be obtained from the datasheet of the actuator used[20].

Based on the spring displacement feedback from ADAMS, the force applied on the driving pulley is estimated. The PID controller then computes the voltage to be applied on the linear actuator based on the error. In order to model actuator voltage limits, a 12 V saturation block was applied to the output of the PID controller. The controller was then tuned for the proportional, integral and derivative gains resulting in the desired operation behavior. The constant retraction force, f_c , was taken to be 1.07 N based on the retraction springs used in the prototype. Thus, to reach the desired head support force,

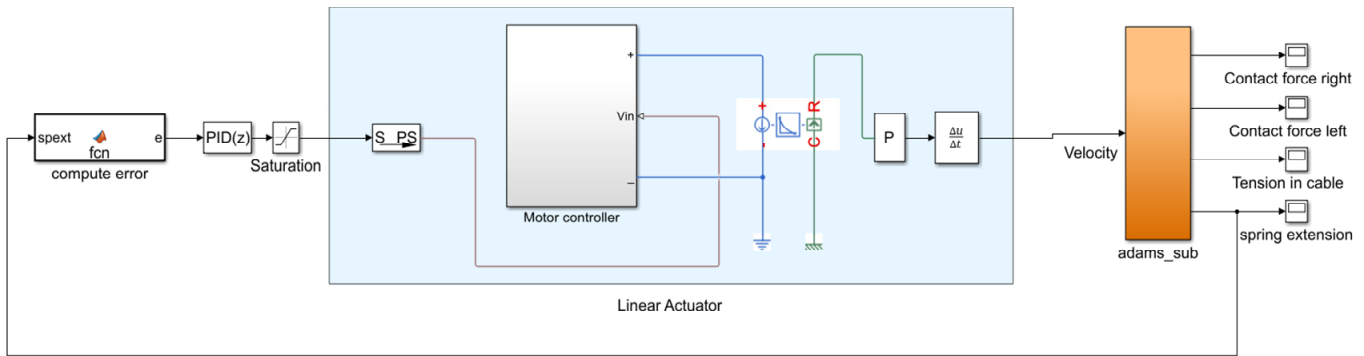

Figure 4. Block diagram of Co-simulation setup

f_{dh} , of 10.0 N we can calculate the desired input force, f_{din} , to be 22.14 N based on equation (2). The overall block diagram of the Co-simulation setup is shown in Fig. 4.

Fig. 5 shows the simulation results with plots of desired head support force, f_{dh} , head support force applied, f_h , desired input force, f_{din} , and input force applied, f_{in} . The retraction springs apply an initial tension on the cable system, which causes f_{in} to go up by $2f_c$ at the start of the simulation. The head support blocks and the human were modeled as rigid bodies in ADAMS, resulting in an impact when they make contact with each other. The head support blocks make contact with the head at exactly 2 seconds, which causes a sudden spike in the f_h due to the impact. However, the spike does not occur in f_{in} values as the spring smoothens out the impact. In a real system, the head support blocks will be made of deformable foam that will prevent an impact when they make

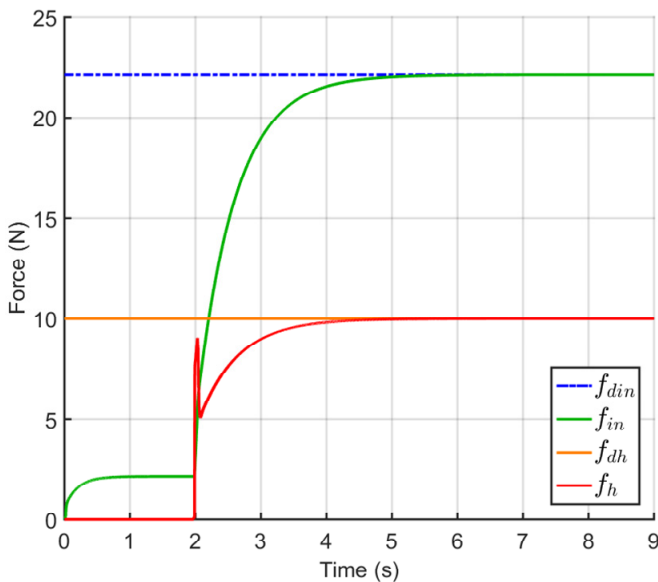

Figure 5. Dynamic co-simulation results for a support force of 10N.

contact with the injured person's head. The control system drives the linear actuator until f_{in} equals f_{din} , at which point f_h matches with f_{dh} . Together the two blocks will apply a total of 20 N support force on the head, which meets the design requirements. In result, the simulation shows that with proper tuning of the control gains the system is able to achieve the desired performance characteristics with a settling time below 5 seconds and steady state error within 0.1 N.

5 PROTOTYPE INTEGRATION

Based on the design goals and results of the simulation, a proof-of-concept prototype was fabricated to test the validity of the controller. Medical-grade foam head immobilization blocks from Morrison Medical were attached to rail-mounted sliding carts. The central pulley was also mounted atop a slider with a tempered steel extension spring ($k = 478.1$ N/m) fixed to the slider. The free end of the extension spring was then attached to a Firgelli LP16 linear actuator, creating a series elastic actuator. The linear actuator provided the draw force to the central pulley, which was then distributed to the head stabilization blocks through the differential mechanism.

The controller was implemented on a Teensy 3.6 microcontroller, which outputs a PWM voltage signal to an H-bridge fed by a 12 VDC power source. In order to provide feedback of the input force, a linear potentiometer was mounted in parallel with the extension spring, which measured the spring deflection. Constant force springs providing 1.07 N restoring force was attached to the head blocks in order to return them to home position once the input actuation is removed.

To validate the force relation between the force applied on the head, f_h , and the input force, f_{in} , a Transducer Techniques MLP-10 single axis load cell was positioned to provide a mechanical stop for the rigid base of the head support blocks. The output signal was conditioned by a TMO-2 +/- 10VDC signal conditioner. A more sophisticated method to measure the force applied directly by foam head support blocks will be the subject of future work. An image of the proof-of-concept prototype may be found in Fig. 6.

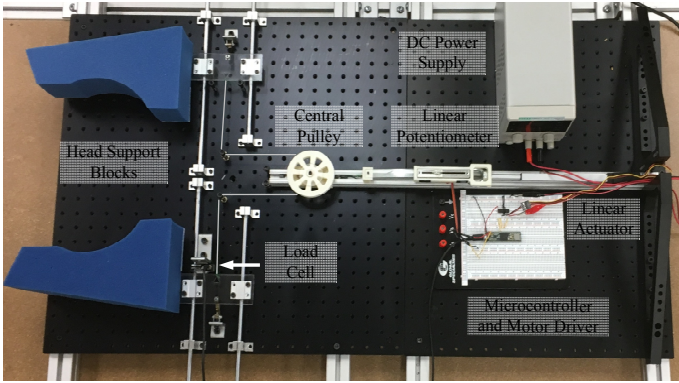

Figure 6. Experimental setup of the head support system

6 EXPERIMENTAL VALIDATION

To validate the control system on a physical prototype, the controller was set at a desired input force f_{din} , to be 22.14 N based on the same calculations as for the simulation. The data was collected from the linear potentiometer and the single axis load cell. The data from the linear potentiometer was used to estimate the total input force to the system at the SEA, f_{in} , as explained in Eq. (3). The force applied by one head block was directly measured by the load cell. The results can be seen in Fig 7.

The results show very similar behavior to that of the simulation. The measured f_{in} , estimated from the extension of the spring starts from approximately 2N due to the tension generated by the retraction springs, which is equal to $2f_c$. During the experiment, the head support blocks make contact at about 3 seconds, which causes an increase in f_{in} starting at 3.5 seconds. The control system then drives f_{in} almost linearly to the desired value of 22.14 N.

The force measured by the load cell, corresponding to the force applied to the head, f_h , varies more from the simulation. The simulated head force shows an impulse due to contact, followed by a short mechanical settling period where the controller continues to apply force. In the experimental results, the measured head force shows no impulse as well as a slight decay in the steady state value. Both behaviors are due to characteristics of load cells and the signal filtration applied to remove high frequency noise. In all, results show that the physical system was able to meet the desired requirements with a settling time less than 8 seconds.

7 CONCLUSION AND FUTURE WORK

This paper presented a control scheme for a novel head stabilization mechanism. Detailed dynamic analysis of the system was done and the proposed control scheme was explained in detail. The dynamic system and controller were co-simulated in MSC ADAMS- Matlab to test the validity of the system. A proof of concept prototype was integrated and the controller was experimentally tested.

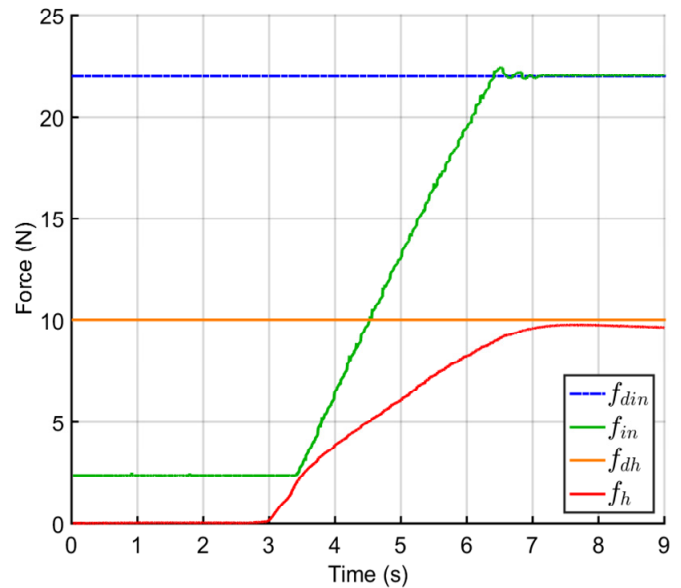

Figure 7. Experimental results for a support force of 10 N

Both the simulation and prototype test indicate that the proposed control scheme meets the design requirements. The system was tested only for the case where the head is held stationary, with no force or position disturbances. Further work on the concept will involve testing the design with disturbances caused due to motion of the platform or due to varying forces exerted by the head on the support blocks. Another key goal of future work will be reducing the overall size of the system using two tiered pulleys to redirect the cables, thus providing a gear reduction and reducing the required motion of the central pulley. Rotating the central pulley and actuation vertically will also be investigated as a space saving method. Additionally, a head-shaped force sensing apparatus will be designed to measure the force applied by the compliant blocks on each point of the head.

ACKNOWLEDGMENTS

This work is supported by the US Army Medical Research & Materiel Command's Telemedicine & Advanced Technology Research Center (TATRC), under Contract No. W81XWH-16-C-0062. The views, opinions, and/or findings contained in this report are those of the authors and should not be construed as an official Department of the Army position, policy, or decision unless so designated by other documentation.

The authors acknowledge Wael Saab and Anil Kumar of RMLab, Virginia Tech, for the input on the initial concepts of the mechanism and for assistance in setting up the physical prototype.

REFERENCES

- [1] Murphy, R. R., Tadokoro, S., and Kleiner, A., 2016, “Disaster Robotics,” *Springer Handbook of Robotics*, Springer International Publishing, Cham, pp. 1577–1604.
- [2] Gilbert, G. R., and Beebe, M. K., 2010, “United States Department of Defense Research in Robotic Unmanned Systems for Combat Casualty Care.”
- [3] Hadley, M. N., Walters, B. C., Grabb, P. A., Oyesiku, N. M., Przybylski, G. J., Resnick, D. K., Ryken, T. C., and Mielke, D. H., 2002, “Guidelines for the Management of Acute Cervical Spine and Spinal Cord Injuries,” *Clin. Neurosurg.*, **49**, pp. 407–498.
- [4] Abram, S., and Bulstrode, C., 2010, “Routine Spinal Immobilization in Trauma Patients: What Are the Advantages and Disadvantages?,” *Surg.*, **8**(4), pp. 218–222.
- [5] Yoo, A. C., Gilbert, G. R., and Broderick, T. J., 2011, “Military Robotic Combat Casualty Extraction and Care,” *Surgical Robotics*, Springer US, Boston, MA, MA, pp. 13–32.
- [6] Theobald, D., 2010, “Mobile Extraction-Assist Robot,” US Patent 7,719,222 B2.
- [7] Hu, J., and Lim, Y.-J., 2014, “Robotic First Responder System and Method,” US Patent 20140150806 A1.
- [8] Beebe, M. K., and Gilbert, G. R., 2010, “Robotics and Unmanned Systems – ‘Game Changers’ for Combat Medical Missions,” *RTO-MP-HFM-182-04*.
- [9] Yim, M., and Laucharoen, J., 2011, “Towards Small Robot Aided Victim Manipulation,” *J. Intell. Robot. Syst.*, **64**(1), pp. 119–139.
- [10] Gallagher, M., Li, K., Terraciano, A., Banisadr, B., Maltese, M., and Jackson, A., “MechaNek” [Online]. Available: www.mechanek.com. [Accessed: 30-Jan-2017].
- [11] Williams, A., Saab, W., and Ben-Tzvi, P., “Analysis of Differential Mechanisms for a Robotic Head Stabilization System,” *Proc. 2017 ASME Int. Design Engineering Technical Conferences & Computers and Information in Engineering Conference IDETC/CIE 2017*, Cleveland, Ohio.
- [12] Jo, I., and Bae, J., 2017, “Design and Control of a Wearable and Force-Controllable Hand Exoskeleton System,” *Mechatronics*, **41**(c), pp. 90–101.
- [13] Almeida, F., Lopes, A., and Abreu, P., 1999, “Force-Impedance Control: A New Control Strategy of Robotic Manipulators,” *Adv. Intell. Mechatronics*, pp. 1–12.
- [14] Luo, R. C., Chang, C. C., and Yi-Wen Perng, 2009, “Impedance Control on a Multi-Fingered Robot Hand Based on Analyzed Electromyographic Information for Massage Applications,” *2009 IEEE International Symposium on Industrial Electronics*, IEEE, pp. 1228–1233.
- [15] Robinson, D. W., Pratt, J. E., Paluska, D. J., and Pratt, G. A., 1999, “Series Elastic Actuator Development for a Biomimetic Walking Robot,” *Proc. 1999 IEEE/ASME Int. Conf. Adv. Intell. Mach.*, pp. 561–568.
- [16] Jyxyvi, S. V., Mrgpyhmrk, Q., Vityfpmwlmrk, V., Qexivmep, X., Ehzivxmwmrk, J. S. V., Tvsqxsmsrep, S. V., Gviexmrk, T., Gspigxmzi, R. I., Sch, S., Mianowski, K., Christian, K., Nejadfard, A., Reichardt, M., and Berns, K., 2016, “RRL AB S EA - A Highly Integrated Compliant Actuator with Minimised Reflected Inertia,” pp. 4–9.
- [17] Pratt, G. A., and Williamson, M. M., 1995, “Series Elastic Actuators,” *Proceedings 1995 IEEE/RSJ International Conference on Intelligent Robots and Systems. Human Robot Interaction and Cooperative Robots*, IEEE Comput. Soc. Press, pp. 399–406.
- [18] Stuke, L. E., Pons, P. T., Guy, J. S., Chapleau, W. P., Butler, F. K., and McSwain, N. E., 2011, “Prehospital Spine Immobilization for Penetrating Trauma—Review and Recommendations From the Prehospital Trauma Life Support Executive Committee,” *J. Trauma Inj. Infect. Crit. Care*, **71**(3), pp. 763–770.
- [19] Bernhardt, P., Wilke, H.-J., Wenger, K. H., Jungkunz, B., Böhm, A., and Claes, L. E., 1999, “Multiple Muscle Force Simulation in Axial Rotation of the Cervical Spine,” *Clin. Biomech.*, **14**(1), pp. 32–40.
- [20] Actuonix Motion Devices Inc., “Actuonix L16 Datasheet,” pp.1–3 [Online]. Available: <https://s3.amazonaws.com/actuonix/Actuonix+L16+Datasheet.pdf>. [Accessed: 06-May-2017].